

Review Article

Internal fixation: An evolutionary appraisal of methods used for long bone fractures

Seemab Mehmood, Umar Ansari*, Murtaza Najabat Ali, Nosheen Fatima Rana

Department of Biomedical Engineering and Sciences, School of Mechanical and Manufacturing Engineering, National University of Sciences and Technology (NUST), Pakistan

***Correspondence Info:**

Umar Ansari
Department of Biomedical Engineering and Sciences,
School of Mechanical and Manufacturing Engineering,
National University of Sciences and Technology (NUST), Pakistan
E-mail: ansari@smme.nust.edu.pk

Abstract

Internal fixation has been playing a pivotal role in orthopedic surgical procedures, yet the evolution of these devices has been relatively short. There is an uprising increase in the instance of trauma and injury. Therefore to accurately ensure the fracture management; fixation or reduction of fracture to reinstate anatomical associations while maintaining the stability of the fixation device and to preserve the blood supply of soft tissues and bone is advantageous. Internal fixation devices offer sustenance until the bone is entirely rehabilitated. These can also be kept throughout the life time of a recipient. This review focuses on an evolutionary perspective of different devices used surgically for the repair of long bone fractures.

Keywords: Internal fixation, metaphyseal, diaphyseal, osteosynthesis

1. Introduction

1.1 Bone fracture

Bone fracture may occur due to diseased conditions like cancer, osteoporosis or external forces causing the bone to lose its integrity by imparting greater impact. The AO system of classification of fractures enlists all the metaphyseal/diaphyseal and articular fractures and their types. Types of fracture include; Simple fracture, open fractures (hard to treat). Comminuted fracture requires insertion of fixation device whereas compound fractures can be healed with fixation plates⁴⁰.

1.2 Fracture Management

There is an uprising increase in the instance of trauma and injury. Therefore to accurately ensure the fracture management; fixation or reduction of fracture to *reinstate anatomical associations* while *maintaining the stability* of the fixation device or the splintage and to *preserve the blood supply* of soft tissues and bone alongside by efficient reduction techniques is advantageous.

Fracture management is of important concern and has been going on since centuries with the concept of fracture healing via plating systems evolving since 1800s. "AO manual of Internal Fixation" proposed in 1965 describes the major goals of fracture management which facilitated to standardize the set of rules for "osteosynthesis". This manual was proposed by the Swiss group of surgeons who formulated an assembly in 1958 known as the "Association for the study of Internal Fixation" (AO/ASIF). The principles stated in the manual were:

- Anatomic Reduction
- Absolute stability with inter-fragmentary compression
- Preservation of blood supply, callus formation through minimal plate to bone contact
- Early mobilisation

There are many treatment modalities as explained below:

1.2.1 External Fixation

Fracture management using a device which is positioned outside the skin to stabilise the bone fragments through wires or pins associated to one or more longitudinal bars / tubes is known as external fixation.

1.2.2 Internal Fixation

Internal fixation devices work on the standard of load sharing either static or cyclic which is either applied through compression or torsion³⁷. Internal fixation devices offer sustenance 'til bone is entirely rehabilitated. These can also be kept throughout the life time of a recipient. Many types of internal fixation devices are accessible

- Wires and Pins:** They are used for the fracture of the small bones e.g. of the foot or hand where large fixation devices are difficult to insert.
- Plates:** They are used for metaphyseal/diaphyseal fractures or too long bone fracture. It works as the splint as external fixation device. It is inserted through the screws and fixation is achieved with the resistance force between the screw and plate.
- Screws:** Screws can be implanted without plate to cure fracture. In any joint fracture or uneven surfaces like knee joint hip joint, pelvis etc., and screws are easy option. Biodegradable screws are also available so that second orthopedic surgery can be avoided.
- Rods:** When bone weakens or loses its strength to sustain load, rods are inserted in to the long bones to provide functional support.

2. Plates for internal fixation of fractures

Plates have been used for over a 100 years for internal fixation of fractures with a trend shifting from rigid fixation of plates to biologic plate fixation until recently. The foundation of plate osteosynthesis was laid in late 19th century. C. Hansmann in 1886 used a fixation plate to treat tibial shaft fractures, with a metal strip prepared of an alloy of tin, nickel and copper and fixed it with screws to the bone fragments.

Figure 1: Lane's plate abandoned because of corrosion (1895)⁵⁹

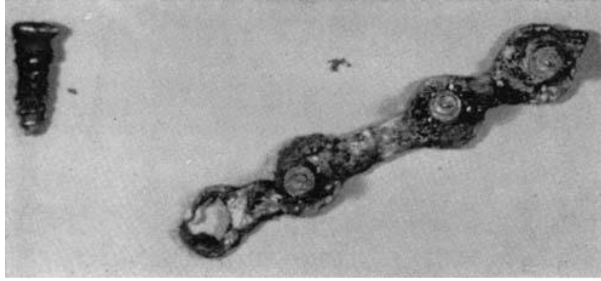

First absolute implantation of plate, made of silver, and screws was carried out by Halsted in 1893. A metal plate was used as an implant by Lane in 1895 (Figure 1)^{59,23}. This subject was soon recognized by Lambotte in 1909 and he recommended a robust alternative of curving of plates (Figure 2) for curved bones along with a tapered, fully threaded screw which now a days is recognised as cortical screw. In 2010, Wullschlegel illustrated in his thesis that Lambotte coined the term for “osteosynthesis” and brought forward the concept of splinting.

Figure 2: Lambotte's plate (1909) is thin, round, and tapered at both ends⁵⁹



A self-tapping screw was proposed by Sherman in 1912, adding a flavour to his own version of vanadium plate for fracture fixation. Another major advancement that occurred in the plate design was by Eggers in 1948 describing the plate to be comprising of two long slots. These slots were for compensating for resorption of fragments. Its use was abandoned due to instability. Uthoff et al, 2006, described that the later three designs presented enhanced corrosion resistance but failed in due course as a result of inadequate strength.

2.1 Compression plating/conventional plating

The concept of compression plating was first demonstrated by Danis in 1949, to accomplish axial compression between bone fragments and rigid fixation hence ultimately providing absolute stability and no callus formation-primary bone healing. The following conclusion was drawn from this research that callus formation was associated with instability. However another compression plate was developed by Bagby and Jane in 1956, which had offset screws that provided interfragmentary compression upon screw tightening. In 1965, Muller et al came up with a parallel design as Bagby and Jane except that it achieved interfragmentary compression by tightening a tensioner fastening the bone to the plate. The aforementioned plate designs suggested the rigid fixation of fracture and absolute stability resulting in bone healing without callus formation. The use of the oval holes proposed by Bagby plate showed success over the Muller's tensioner and led to the development of the first genuine Dynamic Compression Plate by Schenk and Willenegger in 1967.

2.1.1 Dynamic compression plate

One of the earliest successful plating technologies refers to as the “Conventional Plating”. The Dynamic Compression Plate (Figure 3) works on the Dynamic Compression Principle which is described as: contour of the plate holes is akin to an inclined cylinder with the head of the screw descending down this cylinder. The screw head has free vertical movement relative to the bone since it is fixed to the bone through the shaft whereas horizontal movement allocates movement of the bone fragment comparative to the plate for the reason that it has contact with the oblique side of the hole, and eventually leading to compression of the fracture^{45,3,37}.

Figure 3: The special undercuts of the limited-contact dynamic compression plate (LC-DCP) reduced the contact surface by 50% compared to the dynamic compression plate (DCP). The point contact fixator (PC-Fix), was the first internal fixator and had point contact only on the bone surface⁵⁰

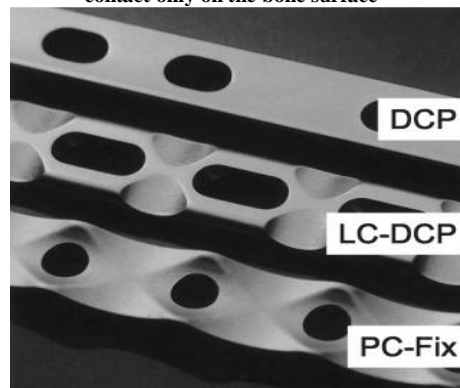

2.1.2 Limited contact - dynamic compression plate

An adjustment of the Dynamic Compression Plate is the Limited-Contact Dynamic Compression Plate (LC-DCP) (Figure 3). It is pro to DCP such that it reduces the contact between the plate and the bone thereby preserving blood supply to an extent^{44, 19, 35} (Perren et al., 1990; Gautier and Ganz, 1994; Leunig et al., 2001). LC-DCP provides bi-directional and more efficient compression than a threaded lag screw. It has uniform hole spacing which is advantageous to provide intra-operative flexibility for screw and bone placement.

2.2 Locked plating/internal fixators

The locked plating technology was brought into existence due to the problems posed by conventional plating. A new generation of internal fixators evolved to overcome the drastic effects of compression forces on periosteum. The advantage of these internal fixators is their locking mechanism resulting in angular stability. This helps in achieving stability and bone healing.

2.2.1 Point contact fixator

One of the novel advancements in internal fixation is the invention of the *Internal Fixator* system commonly known as Point-Contact Fixator (PC-Fix) (Figure 3). It is so called because the implant functions more like a fixator than a plate⁴². Regardless of the similarities in the design of the plate and PC-Fix, the biological and mechanical properties are nevertheless so different making it a better alternative to conventional plating^{57,43}. The innovation in its design is that it acts as an external fixator functionally, minimising the contact, to provide certain advantages such as optimal preservation of blood supply, enhanced fracture healing and improved resistance to infection.

PC-Fix comprises of a narrow plate with a specifically designed under-surface having only small points that come into contact with bone. Due to minimum contact, the atraumatic monocortical screws functions as pegs linking the splint to the bone rather than pressing the splint to the bone to turn out friction i.e. the screw heads are locked into the screw plate, resulting in no compression of plate on the bone^{57,43,54}. A distractor that functions as hinges to consent and preserve the reduction of the fracture fragments whilst the axes are aligned and rotation accustomed, allows for PC-Fix's ease of application^{57, 43}. PC-Fix is an angular-stable screw-plate system because the threaded screw head locks into the plate hole. This system holds the forces from the screw in one main fragment and transmits them through the screw plate construct over the other main fragment^{42,62}.

2.2.2 Less invasive stabilisation system

LISS contributed an additional progress to the internal fixator system consisting of the instrumentation tools (an aiming device), to be used as a safe and reliable procedure^{51,22}. It was specifically designed for distal femur and proximal tibial fractures⁶² with the design depicting anatomical contours of those two areas⁵¹. LISS is implanted using a minimally invasive approach and comprises of self-tapping, monocortical screws^{51,48,29}. These multiple locking head screws in converging and diverging directions provide angular stability^{48,22}. The advantages LISS symbolizes as a high-quality alternative to shun the addition of bone cement to an osteosynthesis⁴⁸. LISS (Figure 4) unlike conventional plates is in minimum contact with the bone therefore exact contouring is not mandatory to fit the bone, which saves the time and lessens the odds for loss of reduction and contributes to callus formation and bony unions. The drawback associated with the use of LISS is that the screws can be positioned perpendicular to the plate only whereas conventional plating allowed screw placement at varying angles³⁷.

Figure 4: LISS: the shape and screw direction of the LISS-DF (distal femur) system for managing distal femoral fractures have been adapted to this zone⁵⁰

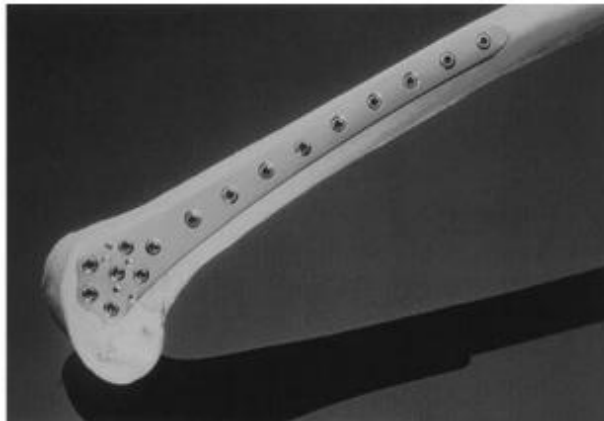

2.2.3 Locking compression plate

The most recent evolutionary development of plate design or internal fixator system is LCP (Figure 5) which is the combination of both plate-screw systems into one system i.e. conventional plating with complete contact between the plate and bone, and internal fixator systems with minimum contact. In 1990, the concepts of DCP, PC-Fix and LISS were merged to develop this Locking Compression Plate by a Group of doctors from Davos of Switzerland^{17,18,40}. The LCP provides three intra-operative options with its combination holes such as it can be used as a compression plate with conventional holes (DCP), as an internal fixator with the threaded holes (LISS) or as a hybrid plate using both holes, depending upon the patient's requirement for instance fracture type and bone rigidity. LCP achieves angular stabilisation via these combination screw holes which can either be self-tapping or self-tapping and self-drilling^{17,59,22,40}. LCP offers certain advantages such as angular stability; better fixation of osteoporotic bone, contouring of plate is not required to fit the bone and less damage to the blood supply. In 2003, Wagner expressed that LCP aims at flexible elastic fixation with the aim of less exposure of the trauma and spontaneous healing due to callus formation. This is achieved by Minimally Invasive Plate Osteosynthesis (MIPO).

- **LCP as a compression plate:** When using LCP as a compression plate with conventional screws, the operative technique is the conventional technique which requires anatomical reduction or open reduction. It is employed for simple fractures and when absolute stability is intended^{60,22}.
- **LCP as an internal fixator:** LCP functions as an internal fixator when the locking threaded screw holes are used and the operative technique is the bridging technique. It provides relative stability when the fracture zone is not exposed rather bridged by the locking plate after indirect reduction. It is used to treat simple as well as multi-fragment fractures^{60,22}.
- **LCP as a hybrid plate:** It is used so when the interfragmentary compression as well as angular stability is required such as in the case of intra-articular fractures or when absolute and relative stability both are required in case of segmental fractures; one simple and other complex^{60,22}.

Figure 5: LCP with conventional and locked screws provides the possibility of treating fractures with conventional standard screws, angular-stable locking head screws, or both⁵⁰

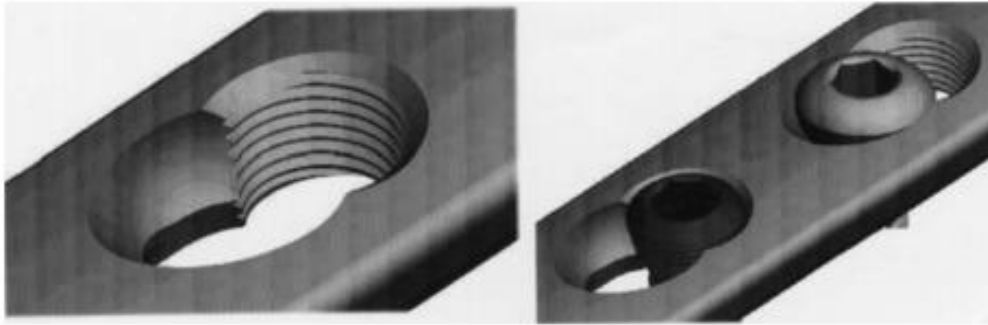

2.3 Semi-rigid carbon-fibre-reinforced plastic plate

Semi-rigid plates (Figure 6) are manufactured to overcome the issues posed by the rigid plates such as that of elimination of motion and no callus formation. Epoxy resin is the CFRP plastic of choice for the production of semi-rigid plates. The plate is fixed to the bone using stainless steel screws. These plates were quite successful in providing desirable movement and external bridging callus appeared producing strong union⁵⁶.

Figure 6: A. Eight hole “standard” design of CFRP plate. B. CFRP plate to illustrate laminated structure and varying directions of carbon fibres within the layers⁵⁶

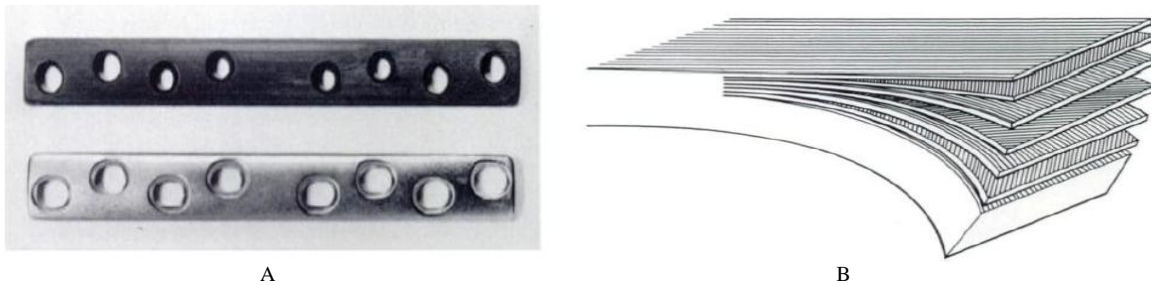

2.4 LESS RIGID PLATES

Fracture healing is fairly slower in rigid plates in contrast to less rigid plates. The dilemma can be overcome by designing a plate that permits micromotion restricted to axial direction and must provide shear, bending and rotational rigidity⁵⁹.

2.4.1 Axially Flexible Plates

Foux illustrated a plate that allowed augmented micromotion in axial direction merely, in 1997. This resulted in provision of compression at the fracture site. These plates (Figure 7) were found to be successful in achieving spontaneous healing as well as the fragments were bridged before time⁵⁹.

Figure 7: Axially flexible plate (AFP) for beagle femors incorporates polymethylmethacrylate (PMMA) cushions between plate and screw head to allow increased micromotion in the axial direction only⁵⁹

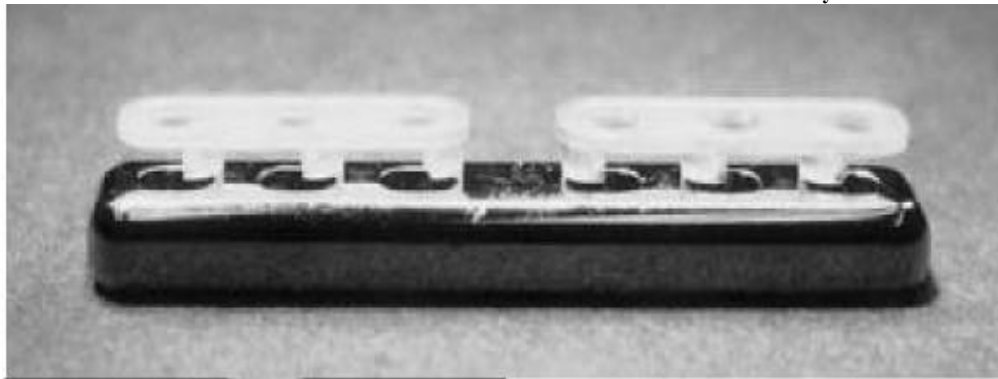

2.4.2 Axially Compressible Plates

After the AFP, it was devised to use a bioresorbable material for manufacturing the cushions, Polylactic acid (PLA) was used for the purpose (Figure 8). The hypothesis was that as the PLA insert went up on to degradation the load would start transmitting from plate to the bone imparting healing of the bone. These plates caused excessive micromotion and delayed union so a successful insert would be the one that would allow union analogous to the biologic union with compact stress shielding^{5,46,59}.

Figure 8: a) Axially compressible plate. Screws (A) and outer shell (B) are titanium, and inserts (C) are polylactic acid (PLA). Inserts allow increased micromotion in the axial plane during union and reduced stress shielding during remodeling as the inserts degrade. b) Cross section of ACP screw (A), outer shell (B), and insert (C). Design allows screw head to subside slightly in bone to reduce plate-bone contact.⁵⁹

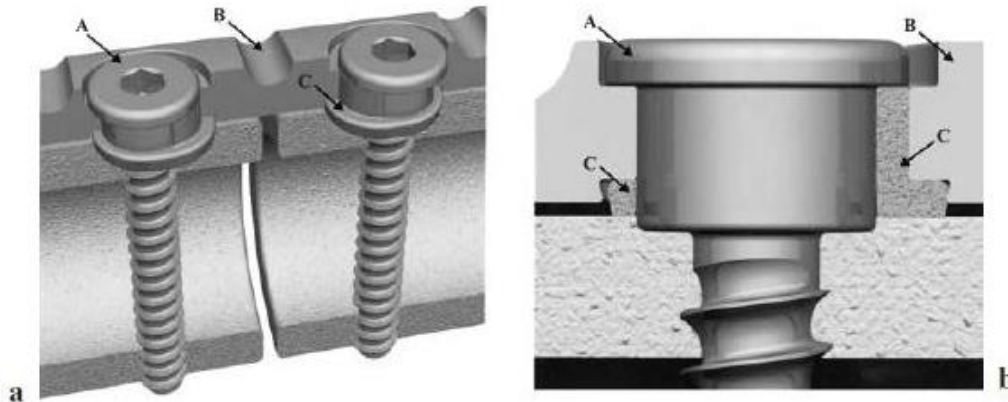

3. Evolution of biological fixation

*Absolute stability*⁴² is a key factor in providing strength to bone healing and experiencing early mobilization. This is achieved through anatomic reduction which usually occurs at the expense of surgical exposure for the reconstruction of the bone and the stabilisation of fracture (ORIF). The compression principle was pulled off through the lag screws and tension devices with the novel AO/ASIF technique. Soon the devices such as Dynamic compression plate (DCP) and Limited contact-dynamic compression plate (LC-DCP) evolved which sanctioned axial compression through introduction of unconventional screws in the plate holes. This was soon followed by “protection plates” which were designed for lag screw protection. The ultimate goal aimed by these plates was primary healing which was a consequence of no callus formation⁵⁰. These techniques however entail large open surgery approaches as well as they tend to adapt the fragments to exact anatomy. Such features ultimately contributed to prolonged healing, infections and non-union.

To overcome the barriers of open reduction, continued research came up with the idea of closed reduction to provide secondary healing and callus formation for fracture fixation and not anatomic reduction and absolute stability. Such theories introduced concepts of providing *relative stability*⁴² to the fracture fragment and no contouring of plate to the bone. With reference to the context the terms such as “biological plate osteosynthesis” and “bridging internal fixation”¹⁹ were postulated by Ganz, characterized as atraumatic surgery at fracture site with minimum incision, indirect reduction and bridge fixation³⁶.

With the continued progress going on in the field of plate osteosynthesis⁶², the concepts of IM nailing and locking nails were also initiated in the middle of 19th century. This led to further innovation in the design of plates and screws. Plates such as “bridging plates” evolved which were in limited contact with the multi-fragment fracture area stabilising the fracture by anchoring it from proximal and distal faces only⁶². By 1980's the AO/ASIF started to work on plate designs to diminish the shortcomings of cortical perfusion. So finally the “internal fixators” (PC-Fix, LISS and LCP) were developed which caused less periosteal damage⁸. And thus the concept of threaded screw heads evolved which fits and locks into the threaded hole in the plate providing the angular stability and introducing the concept of locking mechanism. So as a result of improving the natural environment, the plate mechanics also changed from achieving conventional compression by friction between bone and implant to providing angular stability such that forces on the screws held the fragments in position and these forces travelled through the medium; the plate screw construct^{50,37}.

Thus the main emphasis shifted from *open reduction, absolute stability, rigid fixation and primary healing with no callus formation to closed reduction, relative stability and biological fixation with bridge plating where callus formation* was an important step in bone healing than a mere side effect. And thus the spotlight was on maintaining the biological properties more than mechanical properties. Further advantages include such as preserving arterial vascularity, high rates of union and lower complication rates⁵².

4. Parameters

4.1 Choice of material

Implant material is very significant for the success of internal fixation. Since the early 1800s materials such as ivory, bone, metals such as; copper, bronze, gold, lead were used for implant synthesis for the internal fixation of fractures. Wires, pins and IM nails were the initial devices to be synthesised using these materials. Ivory and bone were found to have lower infection rates and non-unions and they were found to be reabsorbable into the body²³. Thus Nicholas Senn is considered to be the father of biodegradable implants because he prepared a hollow perforated intra-osseous splint using these materials⁷. Silver was also involved in fixation as wires and pins, its first use being reported in 1827²³.

The first plates were prepared of nickel-coated sheet steel, silver, brass, aluminium and vanadium steel. However all the metals pose problems in terms of mechanical properties, corrosion and incompatibility with living tissue. Soon stainless steel and titanium were discovered and were advantageous because of their corrosion resistance, biocompatibility and strength. First implant using stainless steel was synthesised in 1931. Disadvantage of stainless steel includes the fatigue failure. Cobalt alloys have also been used for joint replacement²³.

The biggest disadvantages of metals are their corrosive behaviour²⁸, extreme stiffness which causes stress shielding⁵⁴ and removal of implant after fracture healing⁵⁴. Corrosion results in decrease in fatigue life²⁸. Two types of corrosion are witnessed in metals at screw plate interface. Galvanic corrosion occurs because plate and screw are synthesised from different metals while fretting corrosion occurs due to contact between loads bearing surfaces³⁷.

A recent development in the field of biomaterials involves the research on the metal tantalum. It is remarkably resistant to corrosion and is used to create super-alloys²⁶. Another area of interest is the bioresorbable materials. Research indicates that implants are synthesised using poly-L-lactic acid (PLLA), polyether-etherketone (PEEK), polyglycolic acid, polydioxanone and hydroxylapatite⁵⁴.

4.2 Plate Length

Selection of suitable plate length is one of the foremost aspects in the application of plates. For conventional systems plate length was kept short to avoid tissue damage. With the advent of LCP and MIPO, longer plates are not a problem as there is no incidence of trauma. Plate

length is centred on biomechanical behaviour at fracture site. Plate length and screw placement determines the loading condition which is important for internal fixation. For LCP, perfect plate length is determined by plate span width and plate screw density. The plate span width is described as the quotient of plate length divided by overall fracture length (Figure 9). This quotient should usually be greater than 2-3 for comminuted fractures and higher than 8-10 for simple fractures^{39,37}.

4.3 Number of screws

Screw density is given by the ratio of screws inserted divided by number of plate holes. Its value should be less than 0.4-0.5 (Figure 9). Conventional plates offer a definite number of screws to be used whereas in case of LCP the screws are fixed at proximal and distal ends only. Number of screws inserted should be less to keep the loading low. Monocortical or bicortical screws are often used. Either two monocortical screws or at least one bicortical screw is a preferred choice for each main fragment^{20,39,37}.

Figure 9: A representation for calculating plate span width and plate screw density. Plate span width is shown on the right. Plate screw density is shown on the left. The screw density is given for each bone segment as well as for the entire bone²⁰ (Source: Gautier and Sommer, 2003).

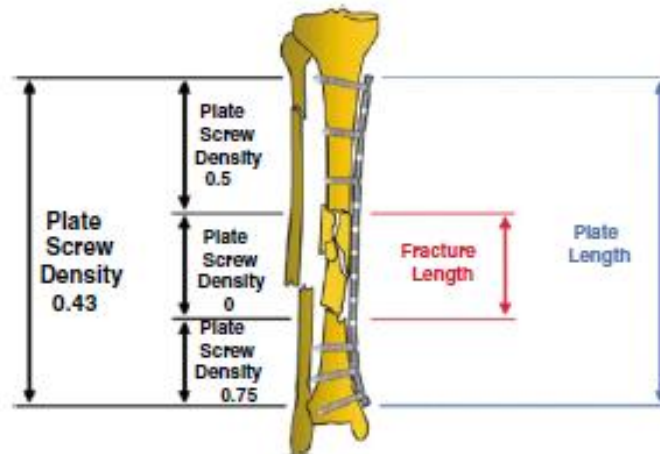

5. Biomechanics of fracture fixation

The precise mechanical purposes of fracture fixation are to deliver stability of fracture reduction, viz., preserve axial alignment and avoid rotation, and to sustain the fracture 'til conclusion of fracture healing. The first objective provides for weight-bearing. While the second objective targets on achieving optimum strength and stiffness of the bone which can't be easily obtained because the strength and stiffness of device shields the bone from normal weight bearing stresses. As the two objectives conflict so we tend to accomplish an optimization between the two.

5.1 Biomechanics of fracture healing - Aspect of necrosis

Fracture healing is an innate refurbishing course of mechanical discontinuity, loss of force transmission and pathological mobility of bone⁴⁵; which results in reconstitution of the injured tissue through sequential changes in tissue development and revival of function¹². Fracture healing can either be primary which occurs in the situations of extreme stability and negligible gap size or secondary which occurs in relation to relative stability. During secondary healing the initial movement is diminished due to increased stiffness and callus formation from periosteum and external soft tissues^{15,42,12,37}.

Wolff's law suggests that stress shielding or unloading of bone causes bone loss near implant site. Perren (2002) describes in his review the correlation between bone porosity and width of contact of implant i.e. increased contact surface results in increased porosity ultimately causing damage to blood supply. Similarly another study elsewhere reported that softer plastic plates producing less unloading had a tighter contact with bone and they enhanced porosity⁴². So we predict that internal remodeling and necrosis are related as it results in porosity in the site of necrotic bone²¹.

Bone necrosis happens as a consequence of trauma. Iatrogenic bone necrosis can either ensue because of the surgical approach to bone or for application of the implant by packing of the endosteum and shedding of the periosteum. These periosteal and endosteal surfaces transport the blood supply to bone, hence an implant which is in contact with the bone along a protracted surface constrains blood reaching or exiting the bone. Thus we infer that area of porosity is associated with the width of the contact of implant. Therefore plates with trapezoidal cross-section helps to reduce area of contact which is demanded as implant contact causes soft tissue necrosis. This can outcome in infection at the site of implant-bone interface due to necrotic tissue. Hence the goal must be to decrease the area of necrosis and to separate areas of contact from each other⁴².

5.2 Biomechanics of fracture stability – A comparison between different plate systems

5.2.1 Locking Compression Plate compared with Conventional Plates

Fracture fixation devices target two main parameters; bony union and early movement following surgery³⁷. Stability is a measure of the degree of load-dependant displacement of fracture surfaces. For fracture management either absolute or relative stability is targeted. For rigid fixation of fractures using conventional plates, the compression is applied at fracture interfaces resulting in no displacement and an augmented resistance to pull out²⁹ which impart absolute stability of fixation⁴². The stability of the conventional plate depends on the friction at the bone-plate interface which is corresponding to the sum of the torques on each screw³⁷. Whereas the internal fixator systems achieve relative stability due to their point contact and flexible fixation as they don't experience compression. Thus relative stability is proportional to the load applied and inversely proportional to the stiffness of the device⁴². The strength of the locking plates is correspondent to the sum of all the bone-screw interfaces³⁷.

Fracture healing and biomechanics have a sound relationship. Pauwels (1960) being the first in his field proposed a theory of tissue differentiation in response to local mechanical stress and strain. In 1979, Perren proposed the concept of strain theory for the stability of the implant. The basic functioning hypothesis of the 'strain' theory suggests that a tissue cannot be created under strain conditions surpassing the elongation at rupture⁶³ of the specified tissue component, such as a cell. The strain theory says that the amount of mobility is more dependent on ratio of displacement and width of fracture gap rather than displacement of fragments alone. It addresses the fracture healing mechanisms such as primary, secondary and non-union³⁷. Primary healing occurs at low strain i.e. 2%, secondary healing at medium strain i.e. 2-10% and callus

formation occurs and thirdly; non-union and resorption at strain more than 10%^{27,42,37}. Hente et al summarised his observations by suggesting that there is lack of mechanical induction of callus formation due to dynamic relative deformation. Similarly for simple and comminuted fractures, the situation of strain differs⁴². Simple fractures usually prefer conventional plating because they experience low strain³⁷. These plates are beneficial for peri-articular fractures which require anatomic reduction enhanced stability for union¹⁴. Multi-fragment fractures are more tolerant to instability because they share displacement⁴ indicating biological fixation and locking plates advantageous for metaphyseal/diaphyseal fractures in osteoporotic bone, indirect reduction, bridging of severely comminuted fractures and plating of fractures where anatomical constraints are an issue¹⁴. Conventional plates convert an axial load to shear stress and locked plates to compressive stress minimizing gap length and strain²¹. Summing it up, we say that both locked and conventional plates have different principles for fracture fixation and consequently they present different biological micro-environment for healing.

5.2.2 Locking Compression Pate compared with Limited Contact-Dynamic Compression Plate

In one study, Belini et al (2002) quoted better fatigue resistance and stiffness of locked plates over the conventional plates. Biomechanical behaviour depends more on plate configuration than plate type. Secondary healing is ensured and the local blood supply is not interrupted. Aguila et al (2005) used canine femurs loaded in four-point bending and torsion or cyclic loading in torsion to accomplish a contrast experiment amongst the LCP and LC-DCP. On the whole, there were no significant differences in bending between the LCP and LC-DCP showed no significant differences in bending as a whole. However in terms of stiffness at the gap, the LCP had upgraded values in lateral-medial bending. It was also found that the LCP outclassed the LC-DCP in rotation to failure such that the LC-DCP failed at a significantly smaller angle.

5.2.3 LCP with Locked and Non-locked screws

Patel carried out a study on the evaluation of Locking Compression Plate with locked and non-locked screws under axial and torsional loading. The results indicated that constructs with locking screws proved to be better. It was found that locking screws increased torsional rigidity of adjacent non-locking screws. In hybrid plates, constructs with locking screws were found to be less loose near the osteotomy gap, showed increased stiffness and deformation than one locking and non-locking screws. Torsional Stiffness and torque was high in locking constructs. FEA analysis showed that induced stresses were least and displacement was maximum on locking plates than non-locking plates.

5.3 Biomechanical effect of type of metal

Certain parameters explained above also contribute to the biomechanical properties of the implants. In 2003, Stoffel et al, carried out a study on the biomechanical behavior of locking compression plates. He pronounced the differences in Von Mises stresses for stainless steel and titanium implants. These stresses were higher for steel when the fracture gap was small and there was no difference when the gap was large. These differences arise because of the varied mechanical stiffness of two metals in combination with motion at fracture site. Stiffness is related to the elastic modulus therefore the large elastic modulus of steel imparts for its greater stiffness as compared to titanium.

Akeson (1975) described a relationship between bone porosity and the modulus of applied plate i.e. decreasing plate stiffness causes decreased bone porosity. A comparison study between stainless steel plates and PMMA plates was conducted by Tonino (1976), which showed plastic plates to have superior mineral mass and mechanical properties.

5.3.1 Standard plate and LCP

Miller and Goswami (2007) explain either to prefer standard plate or LCP for osteoporotic bone. After LCP's success, it is considered to be shinning approach for treatment of weak bone stock. However in a healthy bone, cost might not overshadow the benefits. Summing it up they said that when BMD increases standard plates are preferred whereas if BMD decreases the benefits outweigh the cost and LCP is the gold treatment. So the course of treatment differs for every patient accordingly.

References

1. Aguila AZ, Manos JM, Orlansky AS, Todhunter RJ, Trotter EJ and Van der Meulen MC. In vitro biomechanical comparison of limited contact dynamic compression plate and locking compression plate. *Veterinary Comparative Orthopaedics Traumatology* 2005; 18(4): 220–6.
2. Akeson WH, Woo SL, Coutts RD, Mathews JV, Gonsalves M and Amiel D. Quantitative histologic evaluation of early fracture healing of cortical bones immobilized by stainless steel and composite plates. *Calcified Tissue Research* 1975; 19: 27–37.
3. Allgöwer M, Perren S and Matter P. A new plate for internal fixation—the dynamic compression plate (DCP). *Injury* 1970; 2: 40–7.
4. Aro HT and Chao EYS. Bone-healing patterns affected by loading, fracture fragment stability, fracture type, and fracture site compression. *Clinical Orthopaedics Related Research* 1993; 293: 8–17.
5. Backman D, Uthoff H, Poitras P and Schwamberger A. Mechanical performance of a fracture plate incorporating bioresorbable inserts. *Journal of Bone & Joint Surgery Proceed Br.* 2004; 86:300.
6. Bagby GW and Janes JM. The effect of compression on the rate of fracture healing using a special plate. *American Journal of Surgery* 1958; 95: 761–771.
7. Bartonicek J. Early history of operative treatment of fractures. *Archives of Orthopaedic and Trauma Surgery* 2010; 130: 1385–1396.
8. Baumgaertel F, Perren SM and Rahn B. Animal experimental studies of biological plate osteosynthesis of multi fragment fractures of the femur. *Unfallchirurg* 1994; 97: 19–27.
9. Baumgaertel F, Buhl M and Rahn BA. Fracture healing in biological plate osteosynthesis. *Injury* 1998; 29(3): C3–6.
10. Bellini CM, Raimondi MT, Accetta R and Mineo G. Locked Plating: Biomechanics and Biology. *Techniques in Orthopaedics* 2007; 22: 167–172.
11. Danis R, editor. Théorieetpratique de l'ostéosynthèse. Paris: Masson; 1949.
12. Doblare M, Garcia JM and Gomez MJ. Modelling bone tissue fracture and healing: a review. *Engineering Fracture Mechanics* 2004; 71:1809–1840.
13. Eggers GWN. Internal contact splint. *Journal of Bone & Joint Surgery America* 1948; 30: 40–52.
14. Egol KA, Kubiak EN, Fulkerson E, Kummer FJ and Koval KJ. Biomechanics of Locked Plates and Screws. *Journal Orthopaedic Trauma* 2004; 18(8): 488–493.
15. Einhorn TA. The cell and molecular biology of fracture healing. *Clinical Orthopaedic Related Research.* 1998; 355: S7–S21.
16. Foux A, Yeadon AJ and Uthoff HK. Improved fracture healing with less rigid plates: a biomechanical study in dogs. *Clinical Orthopaedics* 1997; 339: 232–245.
17. Frigg R. Locking Compression Plate (LCP). An osteosynthesis plate based on the Dynamic Compression Plate and the Point Contact Fixator (PC-Fix). *Injury* 2001; 32(2): 63–66.
18. Frigg R. Development of the Locking Compression Plate. *Injury* 2003; 34(2): 6–10.
19. Gautier E and Ganz R. Die biologischeplattenosteosynthese [The biological plate osteosynthesis]. *Zentralbl. Chir.* 1994; 119: 564–572.
20. Gautier E and Sommer C. Guidelines for the clinical application of the LCP. *Injury* 2003; 34(2): B63–76.
21. Gautier E, Perren SM and Cordey J. Effect of plate positionrelative to bending direction on the rigidity of a plate osteosynthesis. A theoretical analysis. *Injury* 2000a; 31: S-C14–S-C20.

22. Gonzalez YH, Martin AD, Sanchez FJ and Erasuns CR. Early results with the new internal fixator systems LCP and LISS: A prospective study. *ActaOrthop. Belg.*, 2007; 73: 60-69.
23. Greenhagen RM, Johnson AR and Joseph A. Internal Fixation: a Historical Review. *Clinis in Podiatrc Medicine and Surgery* 2011; 28: 607–618.
24. Greiwe RM and Archdeacon MT. Locking plate technology: current concepts. *Journal of Knee Surgery* 2007; 20(1): 50–55.
25. Hansmann C. EineneueMethode der Fixierung der FragmentebeikompliziertenFrakturen. *VerhDtschGesChir* 1886; 14: 134–137 [in German].
26. Harrison AK, Gioe TJ, Simonelli C, Tatman PJ and Scholler MC. Do porous tantalum implants help preserve bone? evaluation of tibial bone density surrounding tantalum tibial implants in TKA. *Clinical Orthopaedic Related Research* 2010; 468: 2739–2745.
27. Hente R, Lechner J, Fuechtmeier B. Der einfluss einer zeitlich limitierten kontrollierten bewegung auf die frakturheilung. *Hefte Unfallchirurg*, 2001, 283: 23-24.
28. Jacobs J, Gilbert J and Urban R. Corrosion of metal orthopaedic implants. *Journal of Bone and Joint Surgery America* 1998; 80(2): 268–282.
29. Kolb W, Guhlmann H, Windisch C, Marx F, kolb K and Koller H. Fixation of distal femoral fractures with the Less Invasive Stabilisation System: a minimally invasive treatment with locked fixed-angle screws. *Journal of trauma* 2008; 65: 1425-1434.
30. Krettek C, Schandelmaier P, Miclau T and Tschern H. Minimally invasive percutaneous plate osteosynthesis (MIPPO) using the DCS in proximal and distal femoral fractures. *Injury* 1997; 28(1): 20-30.
31. Lambotte A. Technique et indication des prothèsesdans le traitement des fractures. *Presse Med.* 1909; 17:321.
32. Lane WA. Some remarks on the treatment of fractures. *BMJ.* 1895; 1: 861–863.
33. Lathan SR. Dr. Halsted at Hopkins and at High Hampton. *Proc (Bayl Univ Med Cent)* 2010; 23: 33–7.
34. Leung F and Chow SP. Locking compression plate in the treatment of forearm fractures: a prospective study. *Journal of Orthopaedic Surgery* 2006; 14(3): 291-294.
35. Leunig M, Hertel R, Siebenrock K, Balmer F, Mast J and Ganz R. The evaluation of indirect reduction techniques for the treatment of fractures. *Clinical Orthopaedics* 2001; 375: 7–14.
36. Mast JW, Jakob RP and Ganz R. Planning and reduction technique in fracture surgery. Berlin: Springer. 1989.
37. Miller DL and Goswami D. A review of locking compression plate biomechanics and their advantages as internal fixators in fracture healing. *Clinical Biomechanics* 2007; 22: 1049–1062.
38. Müller ME, Allgöwer M and Willenegger H. Technique of internal fixation of fractures: Compression fixation with plates. *Berlin; Springer.* 1965: 47–51.
39. Niemeyer and Sudkamp. Principles and Clinical Application of the Locking Compression Plate (LCP). *Acta Chirurgiae Orthopaedicae et traumatologiae Cechosl.* 2006; 73.
40. Patel V. Biomechanical Evaluation of Locked and Non-locked Constructs Under Axial and Torsion Loading. Ganpat University, India: 2006.
41. Pauwels F. Eineneuethorieuber den einflubmechanischerreize auf die differenzierung der st utzgewebe. *Z Anat Entwicklungsgeschichte.* 1960; 121: 478–515.
42. Perren SM. Evolution on the internal fixation of long bone fractures. The scientific basis of biological internal fixation: choosing a new balance between stability and biology. *Journal of Bone & Joint Surgery* 2002; 84: 1093–1110.
43. Perren SM and Buchanan JS. Basic concepts relevant to the design and development of the point contact fixator (PC-Fix). *Injury* 1995; 26: SB1–S-B4.
44. Perren SM, Klaue K, Pohler O, Predier M, Steinemann S and Gautier E. The limited contact dynamic compression plate (LC-DCP). *Archives of Orthopaedics Trauma and Surgery* 1990; 109:304–310.
45. Perren SM, Russenberger M, Steinemann S, Müller ME and Allgower M. A dynamic compression plate. *Acta Orthop Scand.* 1969; 125:31–41.
46. Poitras P, Backman D, Uthoff HK and Schwammberger A. Creep properties of a bioresorbable polymer for an axially compressible fracture plate. Presented at the 5th Combined Meeting of the Orthopaedic Research Societies of Canada, USA, Japan and Europe. Banff, AB: 2004.
47. Principles of Bone Healing. American Association of Neurological Surgeons. *Neurosurg Focus* 10(4), 2001.
48. Schandelmaier P, Partenheimer A, Koenemann B, Grün OA and Krettek C. Distal femoral fractures and LISS stabilization. *Injury.* 2001; 3: 55-63.
49. Schenk R and Willenegger H. Morphological findings in primary fracture healing. In: Krompecher S, Kerner E, editors. Callus formation symposium on the biology of fracture healing. Budapest: AkadémiaiKiadó; 1967; 75–86.
50. Schütz M and Südkamp NP. Revolution in plate osteosynthesis: new internal fixator systems. *Journal of Orthopaedic Science.* 2003; 8(2): 252-258.
51. Schütz M, Müller M, Krettek C, Höntzsch D, Regazzoni P, Ganz R and Haas N. Minimally invasive fracture stabilization of distal femoral fractures with the LISS: a prospective multicenter study. Results of a clinical study with special emphasis on difficult cases. *Injury.* 2001; 3: 48-54.
52. Shanmugam C, Rahmatalla A and Maffulli N. Percutaneous Fixation of Distal Tibial Fractures Using Locking Plates. *Techniques in Orthopaedics* 2007; 22(3): 162-166.
53. Sherman WO. Vanadium steel bone plates and screws. *Surg Gynecol Obstet.* 1912; 14: 629–634.
54. Simon JA, Ricci JL and Di Cesare PE. Bioresorbable fracture fixation in orthopedics: a comprehensive review. Part I. Basic science and preclinical studies. *American Journal of Orthopaedics.* 1997; 26(10):665-671.
55. Stoffel K, Dieter U, Stachowiak G, Gachter A and Kuster M. Biomechanical testing of the LCP – how can stability in locked internal fixators be controlled? *Injury* 2003; 34: 11-19.
56. Tayton K, Johnson-Nurse C, McKibbin B, Bradley J and Hastings G. The use of semi-rigid carbon-fibre-reinforced plastic plates for fixation of human fractures. *The Journal of Joint and Bone surgery.* 1982; 64: 105-111.
57. Tepic S and Perren SM. The biomechanics of the PC-Fix internal fixator 1995; 26(2): 5–10.
58. Tonino AJ, Davidson CL, Klopper PJ and Linclau LA. Protection from stress in bone and its effects: Experiments with stainless steel and plastic plates in dogs. *Journal of Bone & Joint Surgery* 1976; 58:107-113.
59. Uthoff HK, Poitras P and Backman DS. Internal plate fixation of fractures: short history and recent developments. *Journal of Orthopaedics and Sciences* 2006; 11(2): 118–126.
60. Wagner M. General principles for the clinical use of the LCP. *Injury* 2003; 34: 31–42.
61. Wagner M, Frenk A and Frigg R. New concepts for bone fracture treatment and the Locking Compression Plate. *Surg Technol Int.* 2004; 12: 271-277.
62. Wullscleger ME. Effects of surgical approach on bone vascularization, soft tissue healing: comparison of less invasive to open approach [dissertation]. Brisbane, Australia: Queensland University of Technology; 2010.
63. Yamada H. *Strength of biological materials.* Baltimore: Williams & Wilkins Co, 1970; 99-104.